

GRAIN DRYER MD-SERIES

(Capacity: 12 ton, 15 ton)



An excellent dry product quality.

- Passed the national type approval testing
- Automatic drying to meet the accurate target moisture level
- Adjustment of the grain circulation speed.
- Excellent drying performance compared to the price level.
- Constant Hot-air supplies constant drying rate.

Main features

- Graphic LCD Touch panel
- Automatic error indication
- Automatic recording program of all operation mode
- Over-loading sensor
- Automatic moisture meter
(Kernel by kernel measuring)
- Impurity cleaning device
- High efficient Turbo Cleaner
(High performance dust extraction)

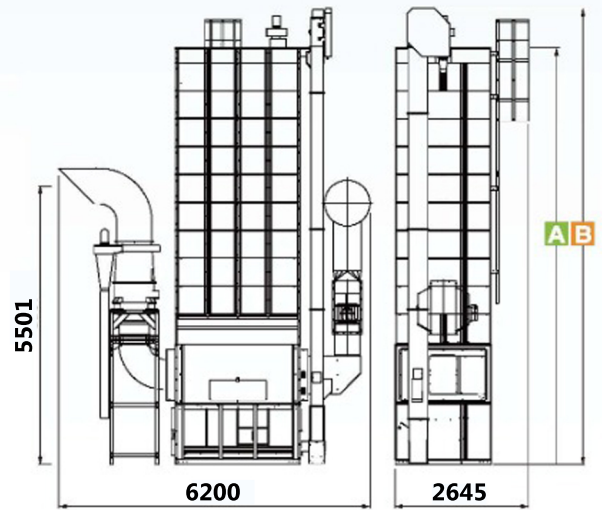

	Model	UNIT	HSD-120MD	HSD-150MD
Size	A	mm	7,260	8,226
	B	mm	8,050	9,003

*The Performance in the Table can be somewhat different according to its working method environment.

(HSD-150MD / 120MD)

Specifications

Model	HSD-120MD	HSD-150MD
Capacity(kg/batch)	5,000 ~ 12,000	5,000 ~ 15,000
Size (LxWxH) (mm)	Turbo cleaner type: 6,200 x 2,645 x 8,050	Turbo cleaner type: 6,200 x 2,645 x 9,003
Electric-Power	Turbo cleaner type (7.5kW) 220V/3P/60Hz, 380V/3P/50Hz, 440V/3P/50Hz	
Loading-time (min)	40 ~ 50	55 ~ 65
Discharge-time (min)	45 ~ 55	60 ~ 70

*Above specification can be changed without notice to promote its function or performance

Turbo Cleaner (for HSD-330HD and HSD-MD Series)

- 2 units (each 7.5kW) of Turbo Cleaner per each Grain Dryer have been applied
- High efficient Turbo Cleaners exhaust moisture and impurities during Dryer operation
- Separated impurities will be collected into Bag or Dust Box (optional)
- This system increases drying efficiency and keeps paddy quality which leads to high rice milling recovery also.
- Reduce investment for Civil Works and Building Construction by minimized installation area and unnecessary dust room

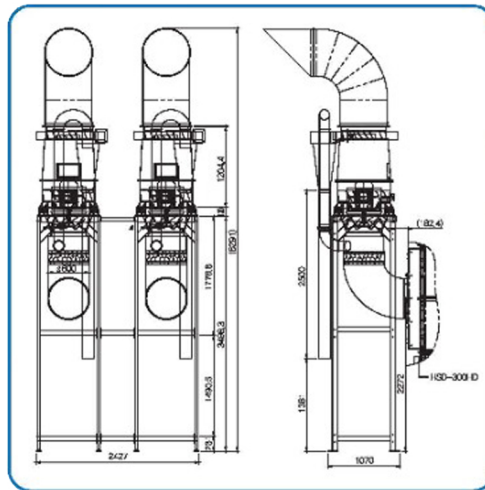
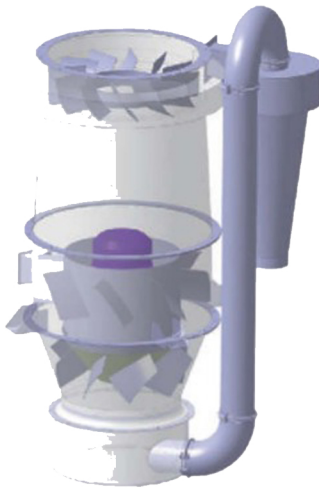

Specifications

HSTC-75V	Size	Electric-Power
	Ø 600 X 1888mm	7.5kW, 3P, 380V

*Above specification can be changed without notice to promote its function or performance

Exclusively Distributed by:

GRAINSCO

Grains Innovation & Solutions Co., Inc.

Manila Office: Unit 206 Veria Bldg.
62 West Avenue, Quezon City 1104 Philippines

CUSTOMER CARE HOTLINES:

FARM MACHINERY: 0917 103-8888 / 0919 088-8883

GRAIN PROCESSING: 0917 101-8888 / 0917 102-8888 / 0919 088-8881

✉ info@grainsco.com

🌐 www.grainsco.com

📘 facebook.com/Grainsco

(HSTC-75V)

