



Destoner.
MTSD.

High separating efficiency. Efficient cleaning.

High versatility.

The Buhler MTSD destoner is applied for efficient separation of stones and pebbles, glass, and other high-density matter from the stream of grain. The throughput capacity will vary as a function of the specific product and its degree of contamination: With soft wheat, a throughput up to 22 t/h can be achieved, with durum wheat up to 14.5 t/h, and with corn/maize up to 16.5 t/h. In addition to the grain varieties mentioned, the destoner is also used to process rye, rice, and soybeans.

High separating efficiency – excellent grain cleaning.

- With its high separating efficiency, the MTSD destoner is capable of efficiently separating even small and light-weight pebbles with the size of a grain from the stream of product, thus ensuring optimal grain cleaning.
- The excellent separation of high-density particles such as stones and pebbles, glass, and metal allows wear and tear of the downstream elements within the production chain to be appreciably reduced.
- Carefully cleaned raw materials are a precondition for achieving a high end product purity and complying with food safety regulations.

Wide variety of applications.

This destoner is characterized by its wide variety of applications: In addition to standard applications with wheat, rye, and corn/maize, the machine can also be used in specialty mills for processing oats, buckwheat, barley, spelt, and millet. The MTSD destoner is even successfully applied in breweries, distilleries, and ethanol production plants.

Tailor-made solutions – optimal customization.

The MTSD destoner is available in three different sizes with a throughput scalability of 2 to 6 t/h, 6 to 12 t/h, or 12 to 22 t/h. It can thus be flexibly adjusted to individual space situations.



MTSD destoner for efficient separation of stones and pebbles.

The advantages at a glance:

- High separating efficiency
- Wide variety of applications
- High product safety

Tailor-made solutions. Wide variety of applications.

The technical data of the Destoner MTSD at a glance:

Model		MTSD-65/120 E	MTSD-65/120	MTSD-120/120
Dimensiones	mm			
A		1600	1600	1600
B		1000	1000	1540
C		1195	1445	1445
D		1545	1805	1805
E		660	660	1200
F		350	350	500
G		120	120	120
Screen width	cm	65	65	120
Screen length	cm	120	120	120
Drive	kW	1 x 0,3	1 x 0,3	2 x 0,3
Negative air pressure	mbar	12	12	12
Approx. weights	kg			
net		310	400	600

Without circulating-air system (Dimensions, technical data, weights, etc.)

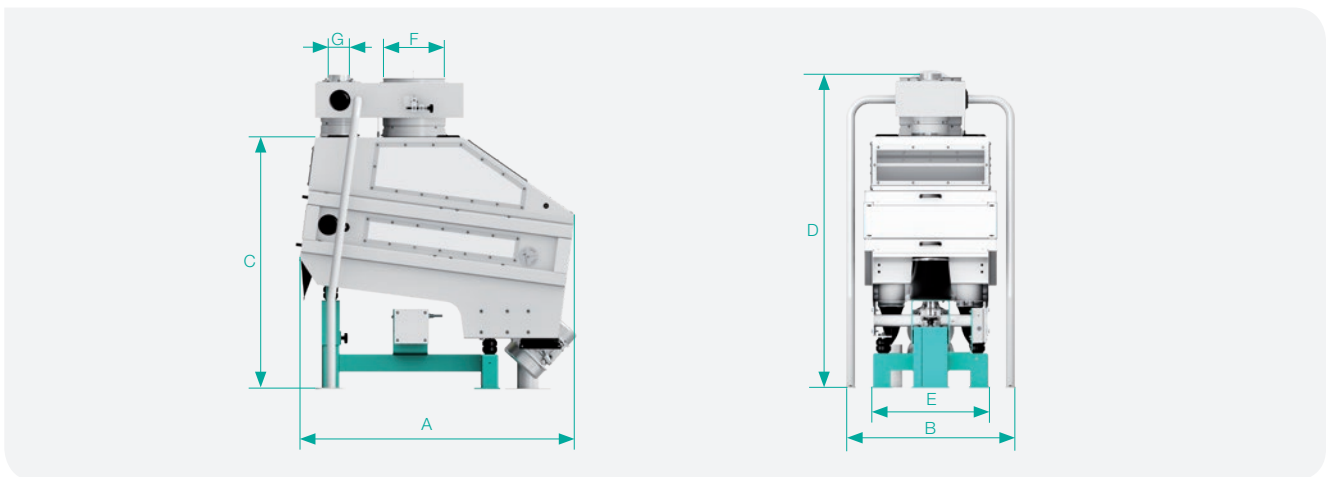

Capacity range:

Model		MTSD-65/120 E	MTSD-65/120	MTSD-120/120
Soft wheat				
Throughput	t/h	6	6 - 12	12 - 22
Aspiration	m ³ /min	70	70	130
Durum				
Throughput	t/h	4	4 - 8	8 - 14,5
Aspiration	m ³ /min	70	70	130
Corn/maize				
Throughput	t/h	4,5	4,5 - 9	9 - 16,5
Aspiration	m ³ /min	70	70	130

The throughput capacity data refer to dry grain in the first cleaning section. E = 1 screen deck

Exclusively Distributed by:

GRAINSCO
Grains Innovation & Solutions Co., Inc.

 **MANILA OFFICE**
Unit 206, Veria Bldg., 62 West Avenue,
Quezon City 1104, Metro-Manila, PH

 **FARM MACHINERY**
0917 101-8888 / 0919 088-8881

 **GRAIN PROCESSING**
0917 103-8888 / 0919 088-8883

 info@grainsco.com

 www.grainsco.com

 facebook.com/Grainsco

 instagram.com/grainscoph

 youtube.com/@grainscoph