

TopHusk™ Huller and Husk Separator

AVHE/DRSD

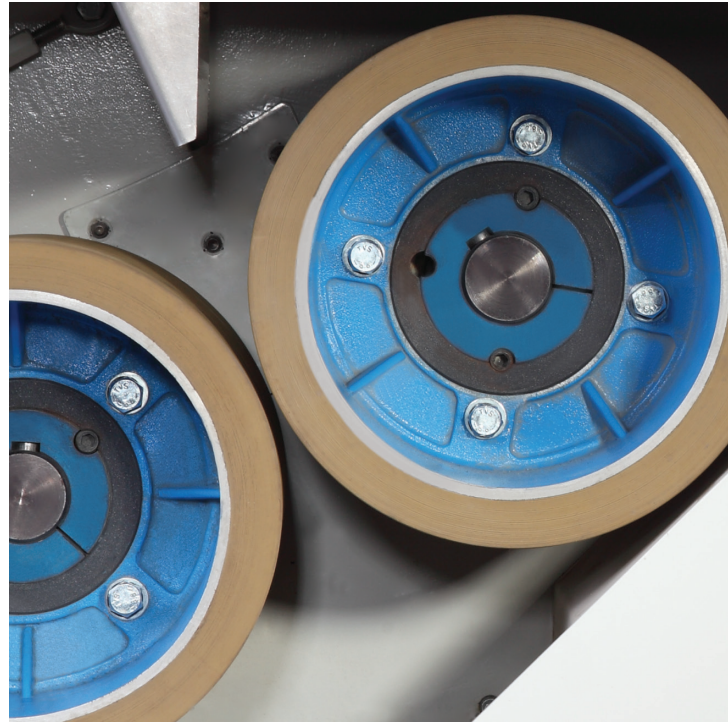

TopHusk.™

• Powerful • Reliable • Compact • Modern



- High head rice yield
- High hulling degree
- High capacity
- Accurate husk separation
- Consistent outlet product quality
- Easy maintenance

Designed to be powerful and reliable - TopHusk, the new compact huller and hull separator from Buhler is a perfect fit in your modern rice mill. TopHusk is well equipped to give your milling process a head start.

Application

The TopHusk™ hulls paddy rice with highest care and efficiency.



Function

A feed point connected to a chute with a vibro feeder guides each grain at optimal speed accurately between the rubber rolls. The huller adjusts its pressure appropriately to adapt to different types of paddy. The aspiration air blows around the rolls for intensive cooling.

The generously sized husk separator works with optimized flow of grains in a closed air circuit to separate the husk from the brown rice accurately. This modern technology finally generates two clean fractions.

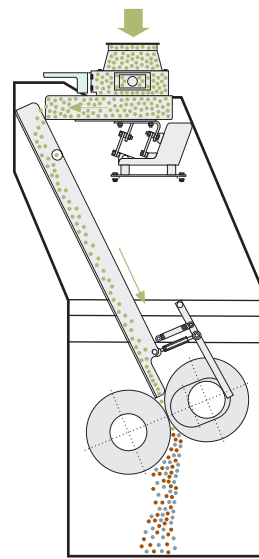

Accurate husk separation

This design eliminates a cumbersome third fraction and achieves accurate husk separation. The process can be easily inspected through the large sight windows and adjusted accurately with the ergonomic levers.

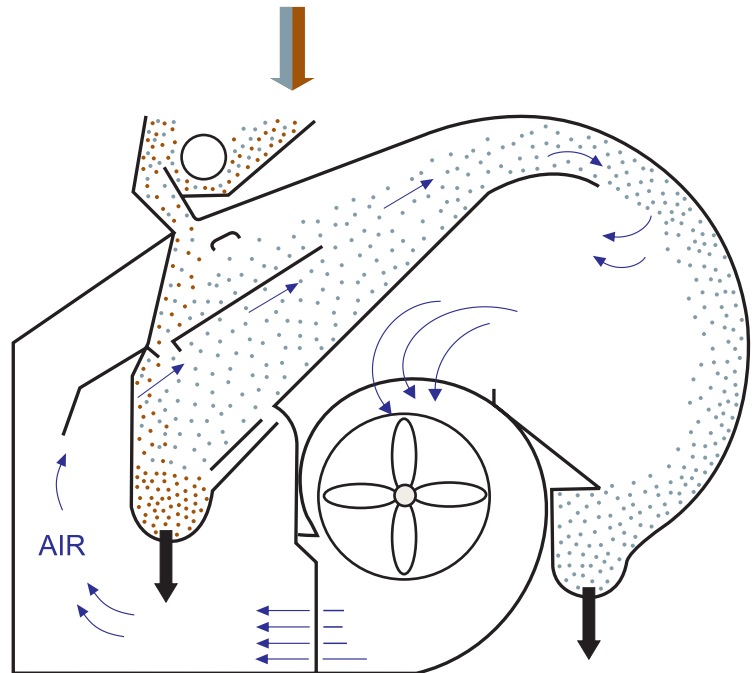

- Paddy
- Brown Rice
- Husk
- Air

TopHusk.™

Give your milling process a head start.

Powerful - Constant high hulling action

- Accurate setting of high hulling degree ensures perfect and constant hulling in high capacity.
- In spite of wear on rubber rollers with corresponding change in ratio, hulling degree remains constant, thus ensuring high head rice yield.
- Automatic hulling pressure control maintains constant hulling degree even under changing roller temperature. This results in steady constant power consumption and longer roller life.

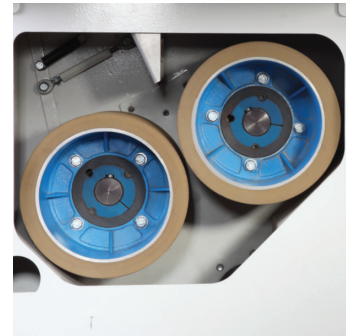

Reliable - High operating performance

- Vibro feeder helps in precise feeding without choking.
- Product pre-acceleration via chute assures minimum breakage at high capacity.
- Automatic feed point control compensates for the roll wear.
- Paddle plates made of high wear-resistant steel.
- Consistent product quality.



Compact - Sturdy and Streamline design

- Motor position at the centre of the swivel arm.
- Even product distribution across separating zone.
- Compact hull separator unit with closed circuit airflow.
- Connection to efficient aspiration system.
- Extra wide machine housing of separator for low specific load of air stream.
- Minimum breakage at high capacity.
- Longer chute length to improve the feeding.

Modern - Easy to operate and maintain

- High-performance Hybrid belt as a standard fitment to provide long service life.
- User friendly touch pad to control feed rate, hulling degree and manual discharge of vibro feeder.
- Automatic disengaging at product flow interruptions.
- Control system with display that shows status and error messages.



TopHusk.™

Technical Data.

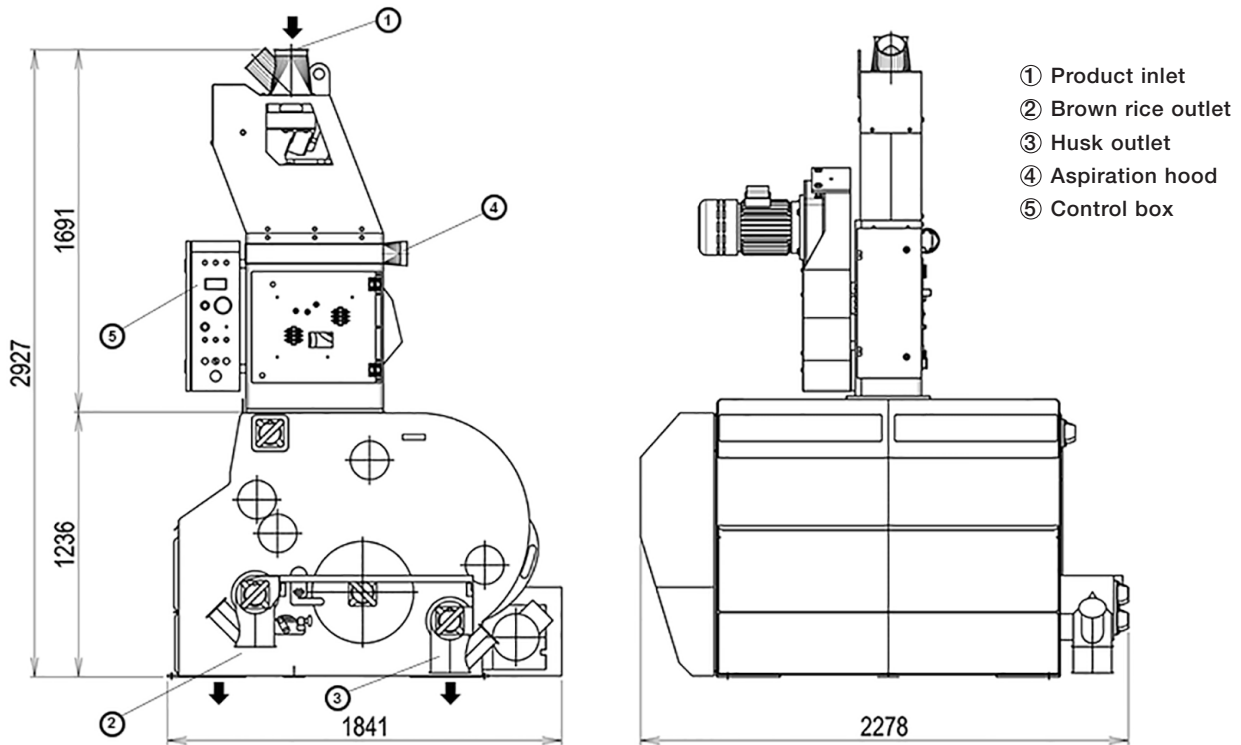

All dimensions in mm

Technical data

Type	Capacity** Kg/h	Motor kW	Aspiration m ³ /min	Approx. weight in kg			Package size
				unpacked	railworthy packing	seaworthy packing	L x W x H
AVHE	3500-7000	7.5	7	650	720	790	1380 x 1220 x 1890
DRSD	3500-7000	4.0	-	960	1160	1260	2480 x 2040 x 1340

*Depending on the type of product and finished product quality

**Capacity as plant paddy input.

Exclusively Distributed by:

GRAINSCO
Grains Innovation & Solutions Co., Inc.

 **MANILA OFFICE**
Unit 206, Veria Bldg., 62 West Avenue,
Quezon City 1104, Metro-Manila, PH

 **FARM MACHINERY**
0917 101-8888 / 0919 088-8881

 **GRAIN PROCESSING**
0917 103-8888 / 0919 088-8883

 info@grainsco.com

 www.grainsco.com

 facebook.com/Grainsco

 instagram.com/grainscoph

 youtube.com/@grainscoph